

## How to Identify Fluid Connectors

**Measuring Tools**—Order part number FT1341 for Aeroquip Tool Kit. A seat angle gauge, thread pitch gauge and an I.D./O.D. caliper are necessary to make accurate measurements of commonly used connectors. Eaton Aeroquip offers a unique new caliper that offers the capabilities of both a caliper and a seat angle gauge in one unit.

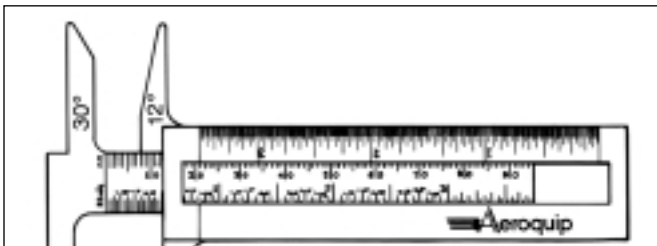

I.D./O.D. Angle Gauge Caliper

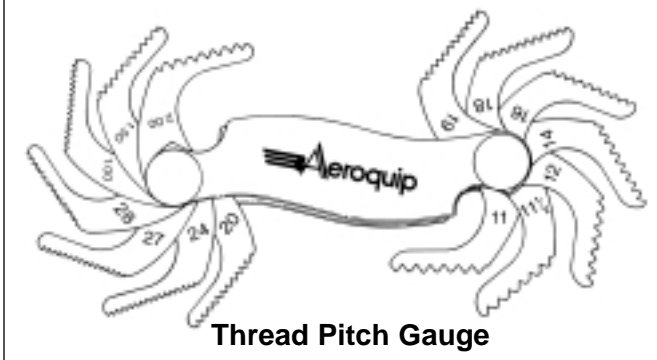

Thread Pitch Gauge

### How to Measure Threads

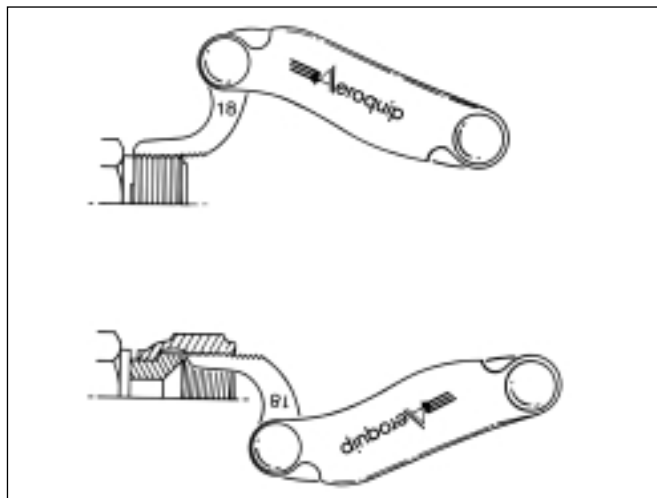

Use a thread pitch gauge to determine the number of threads per inch or the distance between threads in metric connections. Place the gauge on the threads until the fit is snug. Match the measurement to the charts.

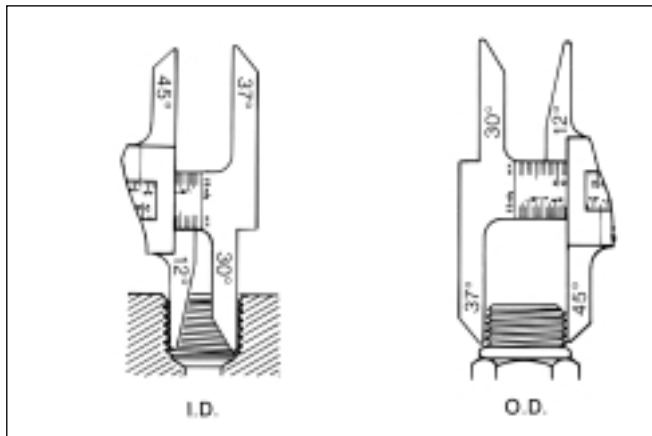

Measure the thread diameter with an I.D./O.D. caliper as shown. Match the measurements to the charts.

### How to Measure Sealing Surface Angles

Female connections are usually measured by inserting the gauge into the connection and placing it on the sealing surface. If the centerlines of the connection and gauge are parallel, the correct angle has been determined.

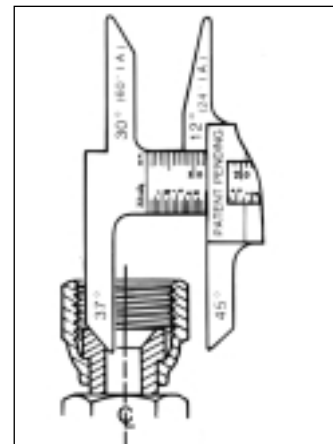

Male flare type connectors are usually measured by placing the gauge on the sealing surface. If the centerlines of the connection and gauge are parallel, the correct angle has been determined.

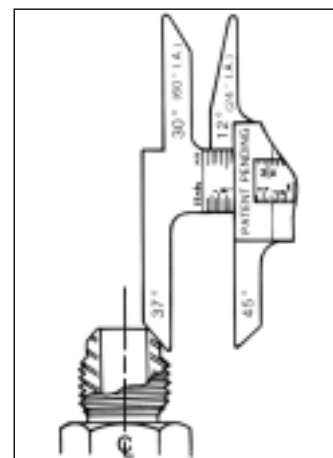

**Thread size chart** The following chart is intended as a quick reference guide for thread size by dash size.

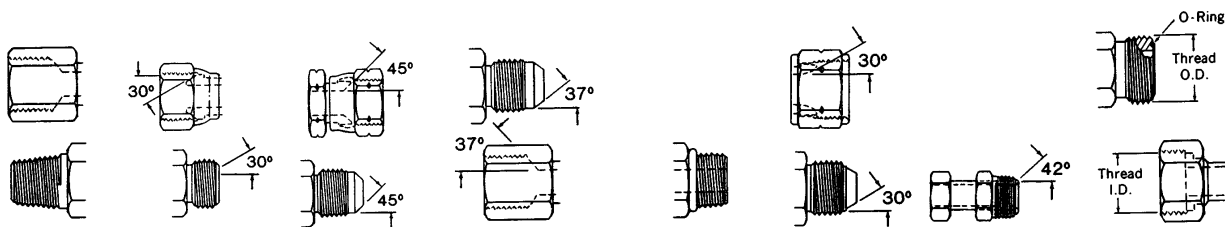

Dash size	N.P.T.F.	N.P.S.M. approx. dia.	SAE 45° auto. refriger.	SAE 37° (J.I.C.) hydraulic	SAE O-Ring boss	P.T.T. 30° automotive	SAE invert. flare	ORS
-02	1/8-27	1/8-27	5/16-24	5/16-24	5/16-24		5/16-24	
-03			3/8-24	3/8-24	3/8-24		3/8-24	
-04	1/4-18	1/4-18	7/16-20	7/16-20	7/16-20		7/16-24	9/16-18
-05			1/2-20	1/2-20	1/2-20		1/2-20	
-06	3/8-18	3/8-18	5/8-18	9/16-18	9/16-18		5/8-18	11/16-16
-07			11/16-24				11/16-18	
-08	1/2-14	1/2-14	3/4-16	3/4-16	3/4-16		3/4-18	13/16-16
-10			7/8-14	7/8-14	7/8-14		7/8-18	1-14
-12	3/4-14	3/4-14	1 1/16-14	1 1/16-12	1 1/16-12		1 1/16-16	1 3/16-12
-14				1 3/16-12	1 3/16-12			
-16	1-11 1/2	1-11 1/2		1 5/16-12	1 5/16-12	1 5/16-14		1 7/16-12
-20	1 1/4-11 1/2	1 1/4-11 1/2		1 5/8-12	1 5/8-12	1 5/8-14		1 11/16-12
-24	1 1/2-11 1/2	1 1/2-11 1/2		1 7/8-12	1 7/8-12	1 7/8-14		2-12
-32	2-11 1/2	2-11 1/2		2 1/2-12	2 1/2-12	2 1/2-12		
-40	2 1/2-8	2 1/2-8		3-12	3-12			
-48	3-8	3-8		3 1/2-12	3 1/2-12			

**Through hole dimensions**

All dimensions are nominal. In jump size bodies, the minimum through hole dimensions will correspond to the smallest dash size.

Dash Size	E through Hole	
	SAE 37°	ORS
-03	.12	
-04	.17	.17
-05	.23	
-06	.30	.26
-08	.39	.38
-10	.48	.48
-12	.61	.61
-16	.84	.81
-20	1.08	1.05
-24	1.31	1.31
-32	1.78	

## How to Measure Non-Threaded connections

**Four Bolt Flange**—First measure the port hole diameter using the caliper. Next, measure the longest bolt hole spacing from center-to-center or measure the flange head diameter.

**Staplok**®—Measure the male diameter with the O.D. portion of the caliper. Measure the female half by inserting the I.D. portion of the caliper into the through hole.

## Dash Numbers

Most fluid piping system sizes in the United States are measured by dash numbers. These are universally used abbreviations for the size of the component expressed as the numerator of the fraction with the denominator always being 16. For example, a -04 port is  $\frac{1}{16}$  or  $\frac{1}{4}$ -inch. Dash numbers are usually nominal (in name only) and are abbreviations that make ordering of components easier.

## American connections

### NPTF (National Pipe Tapered Fuel)

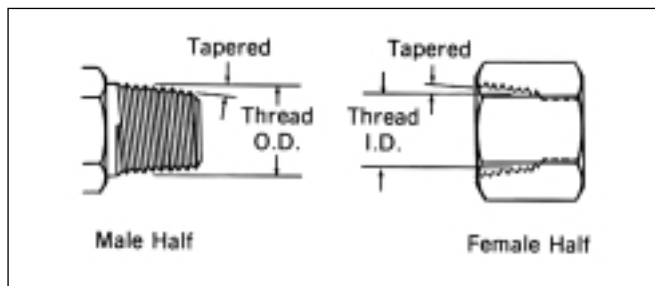

This connection is still widely used in fluid power systems, even though it is not recommended by the National Fluid Power Association (NFPA) for use in hydraulic applications. The thread is tapered and the seal takes place by deformation of the threads.

### NPTF Threads

Measure thread diameter and subtract  $\frac{1}{4}$ -inch to find the nominal pipe size.

Inch Size	Dash Size	Nominal Thread Size	Male Thread O.D. (Inch)		Female Thread I.D. (Inch)	
			Fraction	Decimal	Fraction	Decimal
$\frac{1}{8}$	02	$\frac{1}{8}$ -27	$\frac{13}{32}$	.41	$\frac{3}{8}$	.38
$\frac{1}{4}$	04	$\frac{1}{4}$ -18	$\frac{17}{32}$	.54	$\frac{1}{2}$	.49
$\frac{3}{8}$	06	$\frac{3}{8}$ -18	$\frac{11}{16}$	.68	$\frac{5}{8}$	.63
$\frac{1}{2}$	08	$\frac{1}{2}$ -14	$\frac{27}{32}$	.84	$\frac{25}{32}$	.77
$\frac{3}{4}$	12	$\frac{3}{4}$ -14	$1\frac{1}{16}$	1.05	1	.98
1	16	1-11 $\frac{1}{2}$	$1\frac{5}{16}$	1.32	$1\frac{1}{4}$	1.24
$1\frac{1}{4}$	20	$1\frac{1}{4}$ -11 $\frac{1}{2}$	$1\frac{21}{32}$	1.66	$1\frac{19}{32}$	1.58
$1\frac{1}{2}$	24	$1\frac{1}{2}$ -11 $\frac{1}{2}$	$1\frac{29}{32}$	1.90	$1\frac{13}{16}$	1.82
2	32	2-11 $\frac{1}{2}$	$2\frac{3}{8}$	2.38	$2\frac{5}{16}$	2.30

### NPSM (National Pipe Straight Mechanical)

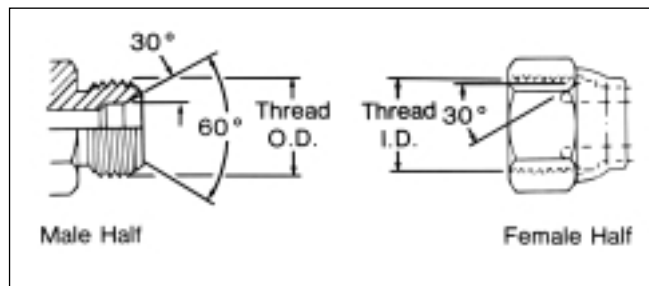

This connection is sometimes used in fluid power systems. The female half has a straight thread and an inverted 30° seat. The male half of the connection has a straight thread and a 30° internal chamfer. The seal takes place by compression of the 30° seat on the chamfer. The threads hold the connection mechanically.

NOTE: A properly chamfered NPTF male will also seal with the NPSM female.

Inch Size	Dash Size	Nominal Thread Size	Male Thread O.D. (Inch)		Female Thread I.D. (Inch)	
			Fraction	Decimal	Fraction	Decimal
$\frac{1}{8}$	02	$\frac{1}{8}$ -27	$\frac{13}{32}$	.41	$\frac{3}{8}$	.38
$\frac{1}{4}$	04	$\frac{1}{4}$ -18	$\frac{17}{32}$	.54	$\frac{1}{2}$	.49
$\frac{3}{8}$	06	$\frac{3}{8}$ -18	$\frac{11}{16}$	.68	$\frac{5}{8}$	.63
$\frac{1}{2}$	08	$\frac{1}{2}$ -14	$\frac{27}{32}$	.84	$\frac{25}{32}$	.77
$\frac{3}{4}$	12	$\frac{3}{4}$ -14	$1\frac{1}{16}$	1.05	1	.98
1	16	1-11 $\frac{1}{2}$	$1\frac{5}{16}$	1.32	$1\frac{1}{4}$	1.24
$1\frac{1}{4}$	20	$1\frac{1}{4}$ -11 $\frac{1}{2}$	$1\frac{21}{32}$	1.66	$1\frac{19}{32}$	1.58
$1\frac{1}{2}$	24	$1\frac{1}{2}$ -11 $\frac{1}{2}$	$1\frac{29}{32}$	1.90	$1\frac{13}{16}$	1.82
2	32	2-11 $\frac{1}{2}$	$2\frac{3}{8}$	2.38	$2\frac{5}{16}$	2.30

## American connections SAE J1926 Straight Thread O-Ring Boss (ORB)

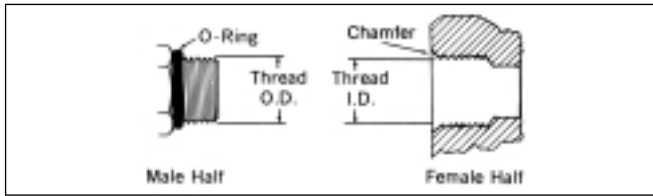

This port connection is recommended by the NFPA for optimum leakage control in medium and high pressure hydraulic systems. The male connector has a straight thread and an O-Ring. The female port has a straight thread, a machined surface (minimum spotface) and a chamfer to accept the O-Ring. The seal takes place by compressing the O-Ring into the chamfer. The threads hold the connection mechanically.

Inch Size	Dash Size	Nominal Thread Size	Male Thread O.D. (Inch)		Female Thread I.D. (Inch)	
			Fraction	Decimal	Fraction	Decimal
1/8	02	5/16-24	5/16	.31	9/32	.27
3/16	03	3/8-24	3/8	.38	11/32	.34
1/4	04	7/16-20	7/16	.44	13/32	.39
5/16	05	1/2-20	1/2	.50	15/32	.45
3/8	06	9/16-18	9/16	.56	17/32	.51
1/2	08	3/4-16	3/4	.75	3/4	.69
5/8	10	7/8-14	7/8	.88	13/16	.81
3/4	12	1 1/16-12	1 1/16	1.06	1	.98
7/8	14	1 3/16-12	1 3/16	1.19	1 1/8	1.13
1	16	1 5/16-12	1 5/16	1.31	1 1/4	1.23
1 1/4	20	1 5/8-12	1 5/8	1.63	1 9/16	1.54
1 1/2	24	1 7/8-12	1 7/8	1.88	1 13/16	1.79
2	32	2 1/2-12	2 1/2	2.50	2 7/16	2.42

## SAE J514 37°\* Hydraulic

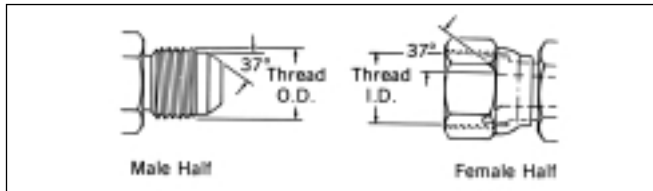

This connection is very common in fluid power systems. Both the male and female halves of the connections have 37° seats. The seal takes place by establishing a line contact between the male flare and the female cone seat. The threads hold the connection mechanically.

**CAUTION:** In the -02, -03, -04, -05, -08 and -10 sizes, the threads of the SAE 45° flare and the SAE 37° flare are the same. However, the sealing surface angles are not the same.

Inch Size	Dash Size	Nominal Thread Size	Male Thread O.D. (Inch)		Female Thread I.D. (Inch)	
			Fraction	Decimal	Fraction	Decimal
1/8	02	5/16-24	5/16	.31	9/32	.27
3/16	03	3/8-24	3/8	.38	11/32	.34
1/4	04	7/16-20	7/16	.44	13/32	.39
5/16	05	1/2-20	1/2	.50	15/32	.45
3/8	06	9/16-18	9/16	.56	17/32	.51
1/2	08	3/4-16	3/4	.75	11/16	.69
5/8	10	7/8-14	7/8	.88	13/16	.81
3/4	12	1 1/16-12	1 1/16	1.06	1	.98
1	16	1 5/16-12	1 5/16	1.31	1 1/4	1.23
1 1/4	20	1 5/8-12	1 5/8	1.63	1 9/16	1.54
1 1/2	24	1 7/8-12	1 7/8	1.88	1 13/16	1.79
2	32	2 1/2-12	2 1/2	2.50	2 7/16	2.42

\*This connection was formerly known as JIC.

## ORS® SAE J1453 O-Ring Face Seal

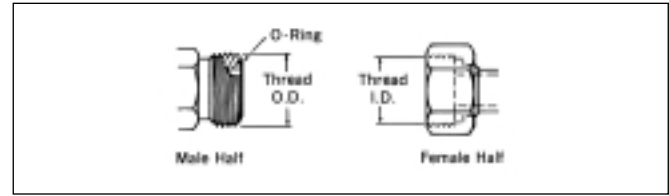

This connection offers the very best leakage control available today. The male connector has a straight thread and an O-Ring in the face. The female has a straight thread and a machined flat face. The seal takes place by compressing the O-Ring onto the flat face of the female, similar to the split flange type fitting. The threads hold the connection mechanically.

Inch Size	Dash Size	Nominal Thread Size	Male Thread O.D. (Inch)		Female Thread I.D. (Inch)	
			Fraction	Decimal	Fraction	Decimal
1/4	04	9/16-18	9/16	.56	17/32	.51
3/8	06	11/16-16	11/16	.69	5/8	.63
1/2	08	13/16-16	13/16	.82	3/4	.75
5/8	10	1-14	1	1.00	15/16	.93
3/4	12	1 3/16-12	1 3/16	1.19	1 1/8	1.11
1	16	1 7/16-12	1 7/16	1.44	1 3/8	1.36
1 1/4	20	1 11/16-12	1 11/16	1.69	1 5/8	1.61
1 1/2	24	2-12	2	2.00	1 15/16	1.92

## SAE J512 Inverted

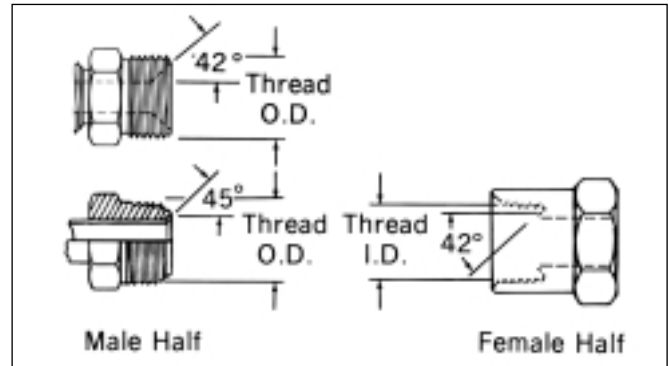

This connection is frequently used in automotive systems. The male connector can either be a 45° flare in the tube fitting form or a 42° seat in the machined adapter form. The female has a straight thread with a 42° inverted flare. The seal takes place on the flared surfaces. The threads hold the connection mechanically.

Inch Size	Dash Size	Nominal Thread Size	Male Thread O.D. (Inch)		Female Thread I.D. (Inch)	
			Fraction	Decimal	Fraction	Decimal
1/8	02	5/16-24	5/16	.32	9/32	.28
3/16	03	3/8-24	3/8	.38	11/32	.34
1/4	04	7/16-24	7/16	.44	13/32	.40
5/16	05	1/2-20	1/2	.50	15/32	.45
3/8	06	5/8-18	5/8	.63	9/16	.57
7/16	07	11/16-18	11/16	.69	5/8	.63
1/2	08	3/4-18	3/4	.75	23/32	.70
5/8	10	7/8-18	7/8	.88	13/16	.82
3/4	12	1 1/16-16	1 1/16	1.06	1	1.00

## SAE J512 45°

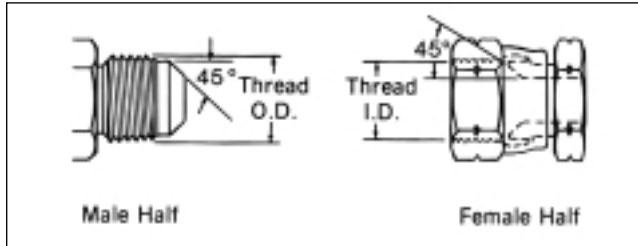

This connection is commonly used in refrigeration, automotive and truck piping systems. The connector is frequently made of brass. Both the male and female connectors have 45° seats. The seal takes place between the male flare the female cone seat. The threads hold the connection mechanically.

CAUTION: In the -02, -03, -04, -05, -08 and -10 sizes, the threads of the SAE 45° flare and the SAE 37° flare are the same. However, the sealing surface angles are not the same.

Inch Size	Dash Size	Nominal Thread Size	Male Thread O.D. (Inch)		Female Thread I.D. (Inch)	
			Fraction	Decimal	Fraction	Decimal
1/8	02	5/16-24	5/16	.31	9/32	.27
3/16	03	3/8-24	3/8	.38	11/32	.34
1/4	04	7/16-20	7/16	.44	13/32	.39
5/16	05	1/2-20	1/2	.50	15/32	.45
3/8	06	5/8-18	5/8	.63	9/16	.57
1/2	08	3/4-16	3/4	.75	11/16	.69
5/8	10	7/8-14	7/8	.88	13/16	.81
3/4	12	1 1/16-14	1 1/16	1.06	1	.99
7/8	14	1 1/4-12	1 1/4	1.25	1 5/32	1.16
1	16	1 3/8-12	1 3/8	1.38	1 9/32	1.29

## Staplok® (SAE J1467)

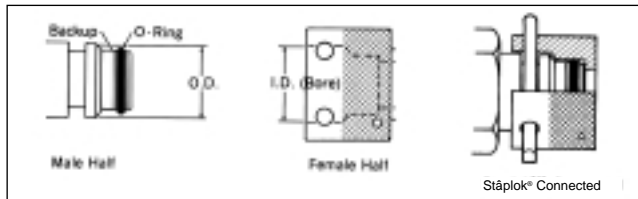

This is a radial O-Ring seal connection developed in Germany and commonly used for hydraulic application in underground mines. The male contains an exterior O-Ring and backup ring, plus a groove to accept the "staple". The female has a smooth bore with two holes for the staple. A "U" shaped retaining clip or staple is inserted through the two holes, passing through the groove in the male to lock the connection together. The seal takes place by contact between the O-Ring in the male and the smooth bore of the female.

Inch Size	Dash Size	Male Thread O.D. (Inch)		Female Thread I.D. (Inch)	
		Fraction†	Decimal	Fraction†	Decimal
1/4	04	19/32	.586	19/32	.597
3/8	06	25/32	.783	51/64	.794
1/2	08	15/16	.940	61/64	.951
3/4	12	1 9/64	1.137	1 9/64	1.148
1	16	1 17/32	1.529	1 35/64	1.540
1 1/4	20	1 13/16	1.806	1 13/16	1.817
1 1/2	24	2 5/32	2.163	2 11/64	2.174
2	32	2 33/64	2.517	2 17/32	2.528

†Measure to the closest 1/64-inch.

## SAE J518 4-Bolt Flange\*

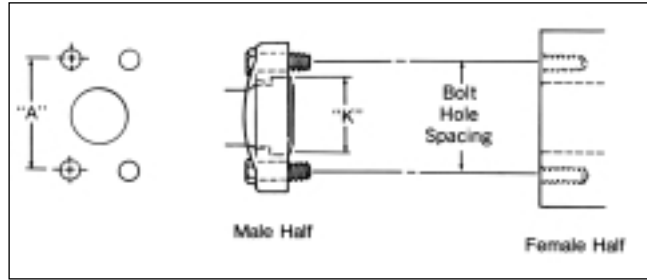

This connection is commonly used in fluid power systems. There are two pressure ratings. Code 61 is referred to as the "standard" series and Code 62 is the "6000 psi" series. The design concept for both series is the same, but the bolt hole spacing and flanged head diameters are larger for the higher pressure, Code 62 connection.

The female (port) is an unthreaded hole with four bolt holes in a rectangular pattern around the port. The male consists of a flanged head, grooved for an O-Ring, and either a captive flange or split flange halves with bolt holes to match the port. The seal takes place on the O-Ring, which is compressed between the flanged head and the flat surface surrounding the port. The threaded bolts hold the connection together.

\*SAE J518, JIS B 8363, ISO/DIS 6162 and DIN 20066 are interchangeable, except for bolt sizes.

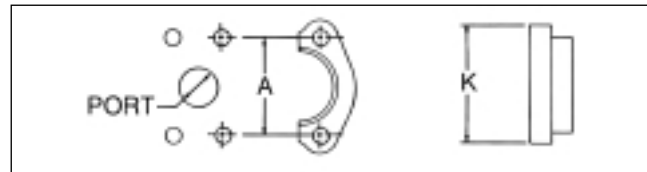

Inch Size (Dash Size)	Port Hole I.D. Inch Fraction (Decimal)	Bolt Dimensions Inch		Bolt Hole Spacing "A" Inch (Decimal)		Flanged Head Diameter "K" Inch (Decimal)	
		Cd. 61	Cd.62	Cd. 61	Cd. 62	Cd. 61	Cd. 62
1/2 (08)	1/2 (.50)	5/16-18x1 1/4	5/16-18x1 1/4	1 1/2 (1.50)	1 19/32 (1.59)	1 3/16 (1.19)	1 1/4 (1.25)
3/4 (12)	3/4 (.75)	3/8-16x1 1/4	3/8-16x1 1/2	1 7/8 (1.88)	2 (2.00)	1 1/2 (1.50)	1 5/8 (1.63)
1 (16)	1 (1.00)	3/8-16x1 1/4	7/16-14x1 3/4	2 1/16 (2.06)	2 1/4 (2.25)	1 3/4 (1.75)	1 7/8 (1.88)
1 1/4 (20)	1 1/4 (1.25)	7/16-14x1 1/2	1/2-13x1 3/4	2 5/16 (2.31)	2 5/8 (2.63)	2 (2.00)	2 1/8 (2.13)
1 1/2 (24)	1 1/2 (1.50)	1/2-13x1 1/2	5/8-11x2 1/4	2 3/4 (2.75)	3 1/8 (3.12)	2 3/8 (2.38)	2 1/2 (2.50)
2 (32)	2 (2.00)	1/2-13x1 1/2	3/4-10x2 3/4	3 1/16 (3.06)	3 13/16 (3.81)	2 13/16 (2.81)	3 1/8 (3.12)

## How to Measure

**Four Bolt Flange**—First measure the port hole diameter using the caliper. Next, measure the longest bolt hole spacing from center-to-center (Dimension "A") or measure the flanged head diameter.

## ISO connections

### ISO/DIS 6162 4-Bolt Flange\*

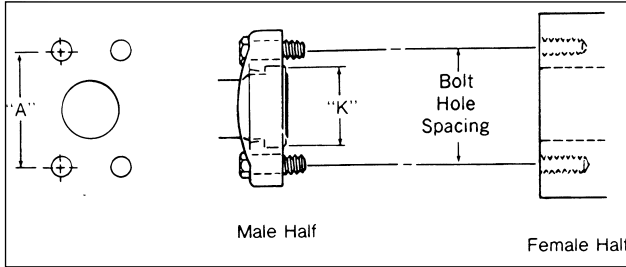

This connection is commonly used in fluid power systems. There are two pressure ratings. PN 35/350 bar (Code 61) is the "standard" series and PN 415 bar (Code 62) is the high pressure series. The design concept for both series is the same, but the bolt hole spacing and flanged head diameters are larger for the higher pressure, PN 415 bar connection. Both metric and inches bolts are used. The port will have an "M" stamped on it if metric bolts are required.

The female (port) is an unthreaded hole with four bolt holes in a rectangular pattern around the port. The male consists of a flanged head, grooved for an O-Ring, and either a captive flange or split flange halves with bolt holes to match the port. The seal takes place on the O-Ring, which is compressed between the flanged head and the flat surface surrounding the port. The threaded bolts hold the connection together.

\*ISO/DIS 6162, DIN 20066, JIS B 8363 and SAE J518 are interchangeable, except for bolt sizes.

Size mm (Inch) [Dash]	Port Hole mm (Inch)	Bolt Dimensions mm and Inch		Bolt Hole Spacing "A" mm (Inch)	
		PN 35/350 Bar (Cd. 61)	PN 415 Bar (Cd. 62)	PN 35/350 Bar (Cd. 61)	PN 415 Bar (Cd. 62)
13 (1/2) [08]	12.7 (.50)	M8 x 1.25 x 30 5/16-18 x 1 1/4	M8 x 1.25 x 30 5/16-18 x 1 1/4	38.10 (1.50)	40.49 (1.57)
19 (3/4) [12]	19.1 (.75)	M10 x 1.5 x 35 3/8-16 x 1 1/4	M10 x 1.5 x 40 3/8-16 x 1 1/2	47.63 (1.88)	50.80 (2.00)
25 (1) [16]	25.4 (1.00)	M10 x 1.5 x 35 3/8-16 x 1 1/4	M12 x 1.75 x 45 7/16-14 x 1 3/4	52.37 (2.06)	57.15 (2.25)
32 (1 1/4) [20]	31.8 (1.25)	M12 x 1.75 x 40 7/16-14 x 1 1/2	M14 x 2 x 50 1/2-13 x 1 3/4	58.72 (2.31)	66.68 (2.63)
38 (1 1/2) [24]	38.1 (1.50)	M14 x 2 x 40 1/2-13 x 1 1/2	M16 x 2 x 55 5/8-11 x 2 1/4	69.85 (2.75)	79.38 (3.13)
51 (2) [32]	50.8 (2.00)	M14 x 2 x 40 1/2-13 x 1 1/2	M20 x 2.5 x 70 3/4-10 x 2 3/4	77.77 (3.06)	96.82 (3.81)

Inch Size	Flanged Head Diameter "K" mm (Inch)	
	PN 35/350 Bar (Cd. 61)	PN 415 Bar (Cd. 62)
1/2	30.18 (1.19)	31.75 (1.25)
3/4	38.10 (1.50)	41.28 (1.63)
1	44.45 (1.75)	47.63 (1.88)
1 1/4	50.80 (2.00)	53.98 (2.13)
1 1/2	60.33 (2.38)	63.50 (2.50)
2	71.42 (2.81)	79.38 (3.13)

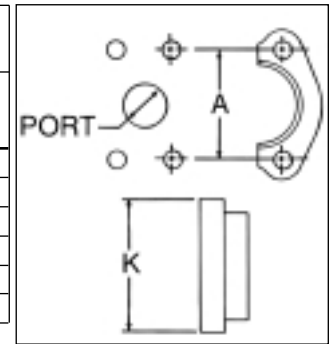

## German connections

### DIN 7631 Series

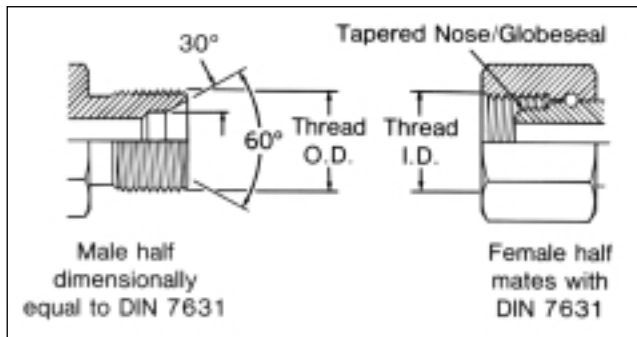

This connection is frequently used in hydraulic systems. The male has a straight metric thread and a 60° (included angle) recessed cone. The female has a straight thread and a tapered nose/Globeseal™ seat. The seal takes place by contact between the cone of the male and the nose of the tapered nose/Globeseal flare-less swivel. The threads hold the connection mechanically.

Use with Pipe/Tube O.D.		Metric Thread Size	Male Thread O.D.		Female Thread I.D.	
mm	Inch		mm	Inch	mm	Inch
6	.24	M12 x 1.5	12	.47	10.5	.41
8	.32	M14 x 1.5	14	.55	12.5	.49
10	.39	M16 x 1.5	16	.63	14.5	.57
12	.47	M18 x 1.5	18	.71	16.5	.65
15	.59	M22 x 1.5	22	.87	20.5	.81
18	.71	M26 x 1.5	26	1.02	24.5	.96
22	.87	M30 x 1.5	30	1.18	28.5	1.12
28	1.10	M38 x 1.5	38	1.50	36.5	1.44
35	1.38	M45 x 1.5	45	1.77	43.5	1.71
42	1.65	M52 x 1.5	52	2.04	50.5	1.99

German connections (cont.)

DIN 3902 Series

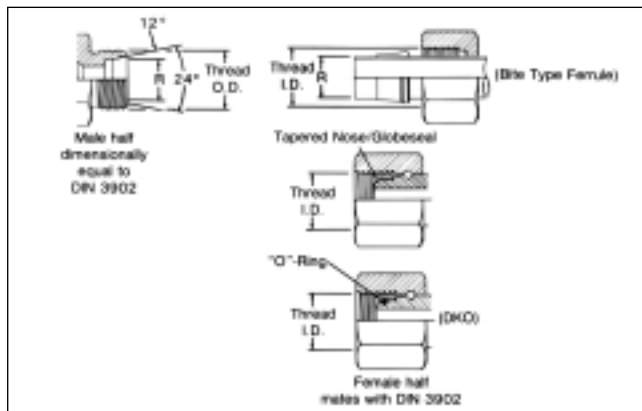

This connection style consists of a common male and three different female halves.

The male has a straight metric thread, a 24° included angle and a recessed counterbore that matches the tube O.D. used with it. The female may be a tube, nut and ferrule, a tapered nose/Globeseal flareless swivel or a tapered nose/Globeseal flareless swivel with an O-Ring in the nose (DKO type).

Tube O.D. "R" Dim. I.Rh.* mm (Inch)	Tube O.D. "R" Dim. s.Rh† mm (Inch)	Metric Thread Size	Male Thread O.D.		Female Thread I.D.	
			mm	Inch	mm	Inch
6 (.24)		M12 x 1.5	12	.47	10.5	.41
8 (.32)	6 (.24)	M14 x 1.5	14	.55	12.5	.49
10 (.39)	8 (.32)	M16 x 1.5	16	.63	14.5	.57
12 (.47)	10 (.39)	M18 x 1.5	18	.71	16.5	.65
	12 (.47)	M20 x 1.5	20	.78	18.5	.73
15 (.59)	14 (.55)	M22 x 1.5	22	.87	20.5	.81
	16 (.63)	M24 x 1.5	24	.94	22.5	.89
18 (.71)		M26 x 1.5	26	1.02	24.5	.96
22 (.87)	20 (.78)	M30 x 2.0	30	1.18	28	1.11
28 (1.10)	25 (.98)	M36 x 2.0	36	1.41	34	1.34
	30 (1.18)	M42 x 2.0	42	1.65	40	1.57
35 (1.38)		M45 x 2.0	45	1.77	43	1.70
42 (1.65)	38 (1.50)	M52 x 2.0	52	2.04	50	1.97

\*I.Rh. is a light duty system.  
†s.Rh. is a heavy duty system.

DIN 20066 4-Bolt Flange\*

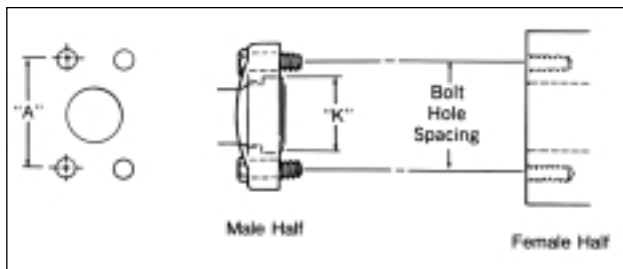

This connection is commonly used in fluid power systems. There are two pressure ratings. Form R (Code 61) is referred to as the "standard duty" series and Form S (Code 62) is the "heavy duty" series. The design concept for both series is the same, but the bolt hole spacing and flanged head diameters are larger for the higher pressure, Form S connection. Both metric and inch bolts are used.

The female (port) is an unthreaded hole with four bolt holes in a rectangular pattern around the port. The male consists of a flanged head, grooved for an O-Ring, and either a captive flange or split flange halves with bolt holes to match the port. The seal takes place on the O-Ring, which is compressed between the flanged head and the flat surface surrounding the port. The threaded bolts hold the connection together.

\*DIN 20066, IS/DIS 6166, JIS B 8363 and SAE J518 are interchangeable, except for bolt sizes.

Size mm (Inch) [Dash]	Port Hole mm (Inch)	Bolt Dimensions mm and Inch		Bolt Hole Spacing "A" mm (Inch)	
		Form R (Cd. 61)	Form S (Cd. 62)	Form R (Cd. 61)	Form S (Cd. 62)
12 (1/2) [08]	12.7 (.50)	M8 x 1.25 x 30 5/16-18 x 1 1/4	M8 x 1.25 x 30 5/16-18 x 1 1/4	38.10 (1.50)	40.49 (1.57)
20 (3/4) [12]	19.1 (.75)	M10 x 1.5 x 30 3/8-16 x 1 1/4	M10 x 1.5 x 40 3/8-16 x 1 1/2	47.63 (1.88)	50.80 (2.00)
25 (1) [16]	25.4 (1.00)	M10 x 1.5 x 35 3/8-16 x 1 1/4	M12 x 1.75 x 45 7/16-14 x 1 3/4	52.37 (2.06)	57.15 (2.25)
32 (1 1/4) [20]	31.7 (1.25)	M10 x 1.75 x 40 7/16-14 x 1 1/2	M14 x 2 x 45 1/2-13 x 1 3/4	58.72 (2.31)	66.68 (2.63)
40 (1 1/2) [24]	38.0 (1.50)	M12 x 1.75 x 40 1/2-13 x 1 1/2	M16 x 2 x 55 5/8-11 x 2 1/4	69.85 (2.75)	79.38 (3.13)
50 (2) [32]	50.8 (2.00)	M12 x 1.75 x 40 1/2-13 x 1 1/2	M20 x 2.5 x 70 3/4-10 x 2 3/4	77.77 (3.06)	96.82 (3.81)

DIN 20066 4-Bolt Flange continued on page 420.

German connections (cont.)

DIN 20066 4-Bolt Flange (cont.)

Inch Size	Flanged Head Diameter "K" mm (Inch)	
	Form R (Cd. 61)	Form S (Cd. 62)
1/2	30.18 (1.19)	31.75 (1.25)
3/4	38.10 (1.50)	41.28 (1.63)
1	44.45 (1.75)	47.63 (1.88)
1 1/4	50.80 (2.00)	53.98 (2.13)
1 1/2	60.33 (2.38)	63.50 (2.50)
2	71.42 (2.81)	79.38 (3.13)

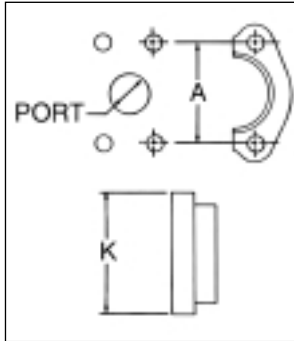

DIN 3852 Metric Threads

Metric Threads	Male Thread O.D. "A"		Female Thread I.D. "B"	
	mm	Inch	mm	Inch
M12 x 1.5	12	.47	10.5	.41
M14 x 1.5	14	.55	12.5	.49
M16 x 1.5	16	.63	14.5	.57
M18 x 1.5	18	.71	16.5	.65
M20 x 1.5	20	.78	18.5	.73
M22 x 1.5	22	.87	20.5	.81
M24 x 1.5	24	.94	22.5	.89
M26 x 1.5	26	1.02	24.5	.96
M27 x 2	27	1.06	25	.98
M30 x 1.5	30	1.18	28.5	1.12
M30 x 2	30	1.18	28	1.10
M33 x 2	33	1.30	31	1.22
M36 x 1.5	36	1.41	34.5	1.36
M36 x 2	36	1.41	34	1.33
M38 x 1.5	38	1.49	36.5	1.43
M38 x 2	38	1.49	36	1.41
M42 x 1.5	42	1.65	40.5	1.60
M42 x 2	42	1.65	40	1.57
M45 x 1.5	45	1.77	43.5	1.71
M45 x 2	45	1.77	43	1.69
M48 x 1.5	48	1.89	46.5	1.83
M48 x 2	48	1.89	46	1.81
M52 x 1.5	52	2.04	50.5	1.89
M52 x 2	52	2.04	50	1.97

DIN 3852 Male Connectors and Female Ports

This DIN is controlled by Germany, but other countries may use it as a reference for their connector and port designs. The chart below illustrates the various forms and how they seal.

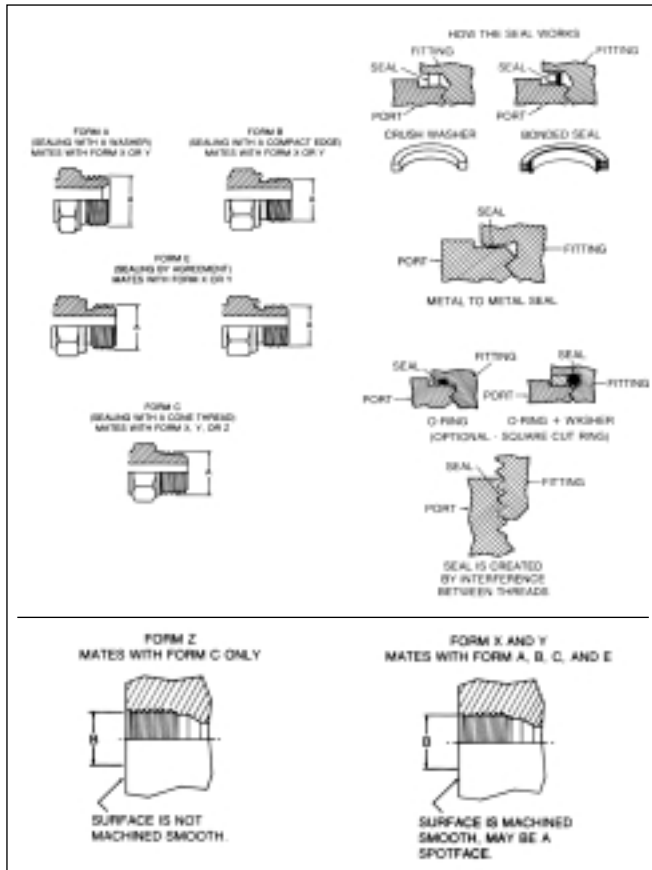

For DIN 3852 Whitworth pipe thread dimensions, see BSPT/BSPP dimensions. They are the same.

## French connections

### Millimetrique and GAZ Series

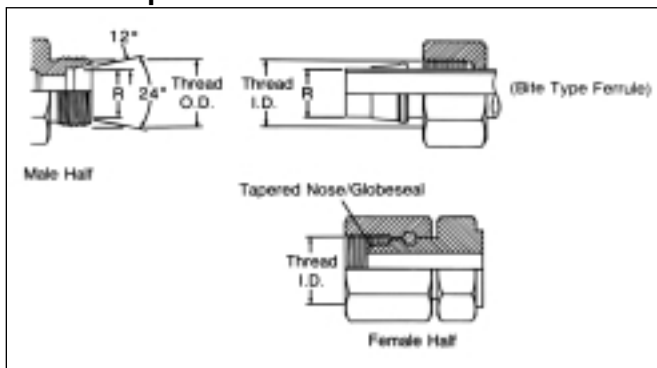

This connection consists of a common male and two different females. The Millimetrique Series is used with whole number metric O.D. tubing and the GAZ Series is used with fractional number metric O.D. pipe size tubing.

### Millimetrique and GAZ Threads

Tubing O.D. "R" Dim. mm (Inch)	"GAZ" Pipe O.D. "R" Dim. mm (Inch)	Metric Thread Size	Male Thread O.D.		Female Thread I.D.	
			mm	Inch	mm	Inch
6 (.24)		M12 x 1.5	12	.47	11	.43
8 (.32)		M14 x 1.5	14	.55	12.5	.49
10 (.39)		M16 x 1.5	16	.63	14.5	.57
12 (.47)		M18 x 1.5	18	.71	16.5	.65
14 (.55)	13.25 (.52)	M20 x 1.5	20	.78	18.5	.73
15 (.59)		M22 x 1.5	22	.87	20.5	.81
16 (.63)	16.75 (.66)	M24 x 1.5	24	.94	22.5	.89
18 (.71)		M26 x 1.5	27	1.06	25.5	1.00
22 (.87)	21.25 (.83)	M30 x 1.5	30	1.18	28.5	1.12
25 (.98)		M33 x 1.5	33	1.30	31.5	1.24
28 (1.10)	26.75 (1.05)	M36 x 1.5	36	1.41	34.5	1.36
30 (1.18)		M39 x 1.5	39	1.54	37.5	1.48
32 (1.25)		M42 x 1.5	42	1.65	40.5	1.60
35 (1.38)	33.50 (1.32)	M45 x 1.5	45	1.77	43.5	1.71
38 (1.50)		M48 x 1.5	48	1.89	46.5	1.83
40 (1.57)	42.25 (1.66)	M52 x 1.5	52	2.04	50.5	1.99
45 (1.77)		M54 x 2.0	54	2.12	52	2.05
	48.25 (1.90)	M58 x 2.0	58	2.28	55	2.16

## British connections

### British Standard Pipe (BSP)

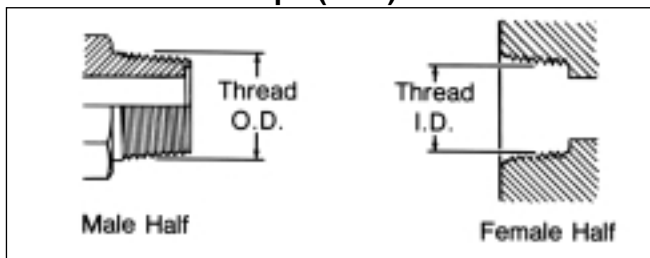

This BSPT (tapered) connection is similar to the NPT, except that the thread pitches are different in most sizes, and the thread form and O.D.s are close but not the same. Sealing is accomplished by thread distortion. A thread sealant is recommended.

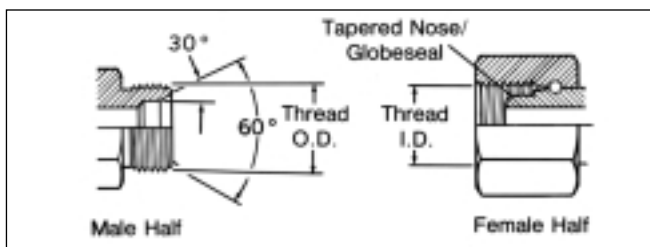

The BSP (parallel) male is similar to the NPSM male except the thread pitches are different in most sizes. The female swivel BSPP has a tapered nose/Globesal flareless swivel which seals on the cone seat of the male.

### BSPT/BSPP Threads

Inch Size	Dash Size	Nominal Thread Size*	Male Thread O.D. (Inch)		Female Thread I.D. (Inch)	
			Fraction	Decimal	Fraction	Decimal
1/8	02	1/8-28	3/8	.38	11/32	.35
1/4	04	1/4-19	33/64	.52	15/32	.47
3/8	06	3/8-19	21/32	.65	19/32	.60
1/2	08	1/2-14	13/16	.82	3/4	.75
5/8	10	5/8-14	7/8	.88	13/16	.80
3/4	12	3/4-14	1 1/32	1.04	31/32	.97
1	16	1-11	1 5/16	1.30	1 7/32	1.22
1 1/4	20	1 1/4-11	1 21/32	1.65	1 9/16	1.56
1 1/2	24	1 1/2-11	1 7/8	1.88	1 25/32	1.79
2	32	2-11	2 11/32	2.35	2 1/4	2.26

\*Frequently, the thread size is expressed as a fractional dimension preceded by the letter "G" or the letter "R". The "G" represents a parallel thread and the "R" indicates a tapered thread. For example, BSPP 3/8-19 may be expressed as G 3/8, and BSPT 3/8-19 may be expressed as R 3/8.

## Japanese connections

### JIS 30° Male Inverted Seat, Parallel Pipe Threads (Threads per JIS B 0202)

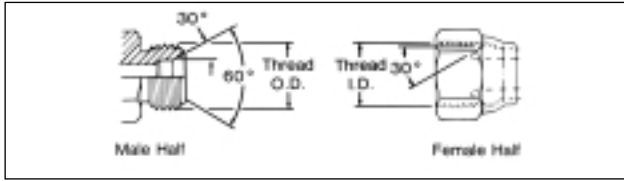

The JIS parallel is similar to the BSPP connection. The JIS parallel thread and the BSPP connection are interchangeable.

Inch Size	Size mm (Dash)	Nominal Thread Size (Similar to BSPP)	Male Thread O.D.		Female Thread I.D.	
			Fraction	mm	Fraction	mm
1/4	6 (04)	1/4-19	33/64	13.2	15/32	11.9
3/8	9 (06)	3/8-19	21/32	16.7	19/32	15.3
1/2	12 (08)	1/2-14	13/16	21.0	3/4	19.2
3/4	19 (12)	3/4-14	11/32	26.4	31/32	24.6
1	25 (16)	1-11	15/16	33.3	17/32	30.9
1 1/4	32 (20)	1 1/4-11	121/32	41.9	19/16	39.6
1 1/2	38 (24)	1 1/2-11	17/8	47.8	125/32	45.5
2	50 (32)	2-11	211/32	59.7	21/4	57.4

### JIS 30° Male (Inverted) Seat, Metric Threads (Threads per JIS B 0207)

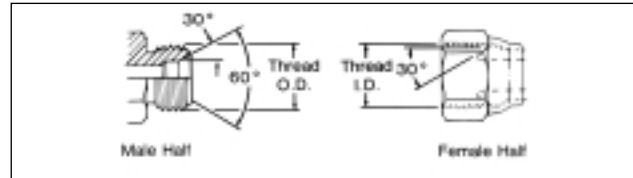

The JIS parallel (metric) is the same as the JIS parallel (PF), except for the thread difference.

Size mm	Dash Size Equivalent	Thread Size	Male Thread O.D.		Female Thread I.D.	
			mm	Inch	mm	Inch
6	04	M14 x 1.5	14	.55	12.5	.49
9	06	M18 x 1.5	18	.71	16.5	.65
12	08	M22 x 1.5	22	.87	20.5	.81
19	12	M30 x 1.5	30	1.18	28.5	1.12
25	16	M33 x 1.5	33	1.30	31.5	1.24
32	20	M42 x 1.5	42	1.65	40.5	1.60

### JIS Tapered Pipe (PT) (Threads per JIS B 0203)

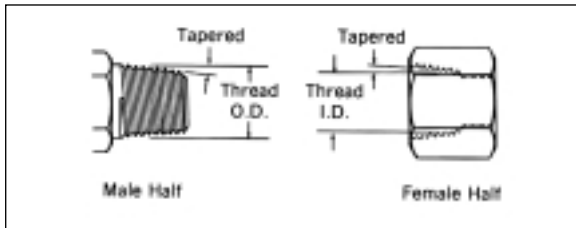

The JIS tapered thread is similar to the BSPT connection in design, appearance and dimensions. The JIS tapered thread and the BSPT connection are interchangeable.

Inch Size	Size mm (Dash)	Nominal Thread Size (Similar to BSPT)	Male Thread O.D.		Female Thread I.D.	
			Fraction	mm	Fraction	mm
1/4	6 (04)	1/4-19	33/64	13.2	15/32	11.9
3/8	9 (06)	3/8-19	21/32	16.7	19/32	15.3
1/2	12 (08)	1/2-14	13/16	21.0	3/4	19.2
3/4	19 (12)	3/4-14	11/32	26.4	31/32	24.6
1	25 (16)	1-11	15/16	33.3	17/32	30.9
1 1/4	32 (20)	1 1/4-11	121/32	41.9	19/16	39.6
1 1/2	38 (24)	1 1/2-11	17/8	47.8	125/32	45.5
2	50 (32)	2-11	211/32	59.7	21/4	57.4

## JIS 30° Female (Cone) Seat, Parallel Pipe Threads (Threads per JIS B 0202)

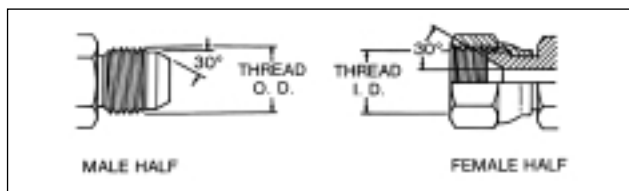

The Japanese JIS 30° flare is similar to the American SAE 37° flare connection in application as well as sealing principles. However, the flare angle and dimensions are different. The threads are similar to BSPP.

Inch Size	Size mm (Dash)	Nominal Thread Size (Similar to BSPP)	Male Thread O.D. (Inch)		Female Thread I.D. (Inch)	
			Fraction	mm	Fraction	mm
1/4	6 (04)	1/4-19	33/64	13.2	15/32	11.9
3/8	9 (06)	3/8-19	21/32	16.7	19/32	15.3
1/2	12 (08)	1/2-14	13/16	21.0	3/4	19.2
3/4	19 (12)	3/4-14	1 1/32	26.4	31/32	24.6
1	25 (16)	1-11	1 5/16	33.3	1 7/32	30.9
1 1/4	32 (20)	1 1/4-11	1 21/32	41.9	1 9/16	39.6
1 1/2	38 (24)	1 1/2-11	1 7/8	47.8	1 25/32	45.5
2	50 (32)	2-11	2 11/32	59.7	2 1/4	57.4

## JIS B 8363 4-Bolt Flange\*

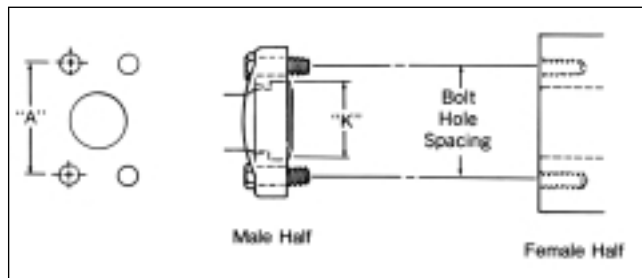

This connection is commonly used in fluid power systems. There are two pressure ratings. Type I (Code 61) is referred to as the "standard" series and Type II (Code 62) is the "6000 psi" series. The design concept for both series is the same, but the bolt hole spacing and flanged head diameters are larger for the higher pressure, Type II connection. Both metric and inch bolts are used.

The female (port) is an unthreaded hole with four bolt holes in a rectangular pattern around the port. The male consists of a flanged head, grooved for an O-Ring, and either a captive flange or split flange halves with bolt holes to match the port. The seal takes place on the O-Ring, which is compressed between the flanged head and the flat surface surrounding the port. The threaded bolts hold the connection together.

\*JIS B 8363, ISO/DIS 6162, DIN 20066, and SAE J518 are interchangeable, except for bolt sizes.

Size mm (Inch) [Dash]	Port Hole mm (Inch)	Bolt Dimensions mm and Inch		Bolt Hole Spacing "A" mm (Inch)	
		Type I (Cd. 61)	Type II (Cd. 62)	Type I (Cd. 61)	Type II (Cd. 62)
12 (1/2) [08]	12.7 (.50)	M8 x 1.25 x 30 5/16-18 x 1 1/4	M8 x 1.25 x 30 5/16-18 x 1 1/4	38.10 (1.50)	40.49 (1.57)
19 (3/4) [12]	19.1 (.75)	M10 x 1.5 x 30 3/8-16 x 1 1/4	M10 x 1.5 x 40 3/8-16 x 1 1/2	47.63 (1.88)	50.80 (2.00)
25 (1) [16]	25.4 (1.00)	M10 x 1.5 x 30 3/8-16 x 1 1/4	M12 x 1.75 x 45 7/16-14 x 1 3/4	52.37 (2.06)	57.15 (2.25)
32 (1 1/4) [20]	31.7 (1.25)	M10 x 1.5 x 40 7/16-14 x 1 1/2	M14 x 2 x 45 1/2-13 x 1 3/4	58.72 (2.31)	66.68 (2.63)
38 (1 1/2) [24]	38.0 (1.50)	M12 x 1.75 x 40 1/2-13 x 1 1/2	M16 x 2 x 55 5/8-11 x 2 1/4	69.85 (2.75)	79.38 (3.13)
50 (2) [32]	50.8 (2.00)	M12 x 1.75 x 40 1/2-13 x 1 1/2	M20 x 2.5 x 70 3/4-10 x 2 3/4	77.77 (3.06)	96.82 (3.81)

Inch Size	Flanged Head Diameter "K" mm (Inch)	
	Type I (Cd. 61)	Type II (Cd. 62)
	1/2	30.18 (1.19)
3/4	38.10 (1.50)	41.28 (1.63)
1	44.45 (1.75)	47.63 (1.88)
1 1/4	50.80 (2.00)	53.98 (2.13)
1 1/2	60.33 (2.38)	63.50 (2.50)
2	71.42 (2.81)	79.38 (3.13)

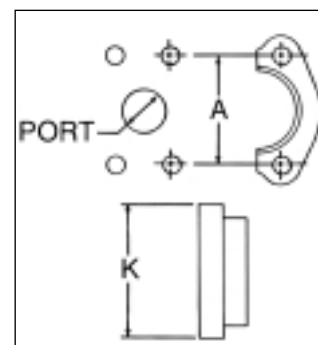

### Japanese connections (continued)

#### JIS 210 Kg/cm<sup>2</sup> 4-Bolt Square Flange

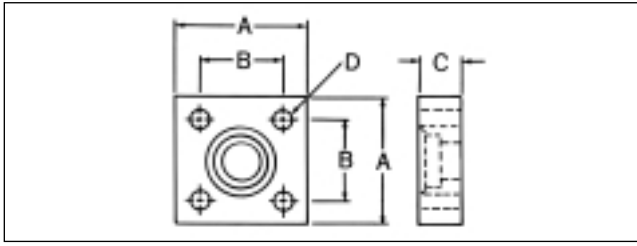

The JIS 4-bolt square flange connection is similar in concept to the SAE 4-bolt flange connection, except that the JIS bolt pattern is square and the flange itself is different.

Size mm	Approx. Inch Size	Bolt Size mm (Bolt Length for Long Design)	Dim. "A" mm (Inch)	Dim. "B" mm (Inch)	Dim. "C" mm (Inch)	Bolt Hole Dia. "D" mm (Inch)
12	1/2	M10 x 1.5 x 55 (80)	63 (2.48)	40 (1.57)	22 (.87)	11 (.43)
19	3/4	M10 x 1.5 x 55 (80)	68 (2.67)	45 (1.77)	22 (.87)	11 (.43)
25	1	M12 x 1.75 x 70 (100)	80 (3.15)	53 (2.09)	28 (1.10)	13 (.51)
32	1 1/4	M12 x 1.75 x 70 (100)	90 (3.54)	63 (2.48)	28 (1.10)	13 (.51)
38	1 1/2	M16 x 2.0 x 90 (130)	100 (3.94)	70 (2.76)	36 (1.42)	18 (.71)
50	2	M16 x 2.0 x 90 (130)	112 (4.41)	80 (3.15)	36 (1.42)	18 (.71)

#### JIS 210 Kg/cm<sup>2</sup> O-Ring

Nominal Size mm	Dim. "D" mm	Dim. "W" mm
12	24.4 ± 0.15	3.1 ± 0.1
19	29.4 ± 0.15	3.1 ± 0.1
25	34.4 ± 0.15	3.1 ± 0.1
32	39.4 ± 0.15	3.1 ± 0.1
38	49.4 ± 0.15	3.1 ± 0.1
50	59.4 ± 0.15	3.1 ± 0.1

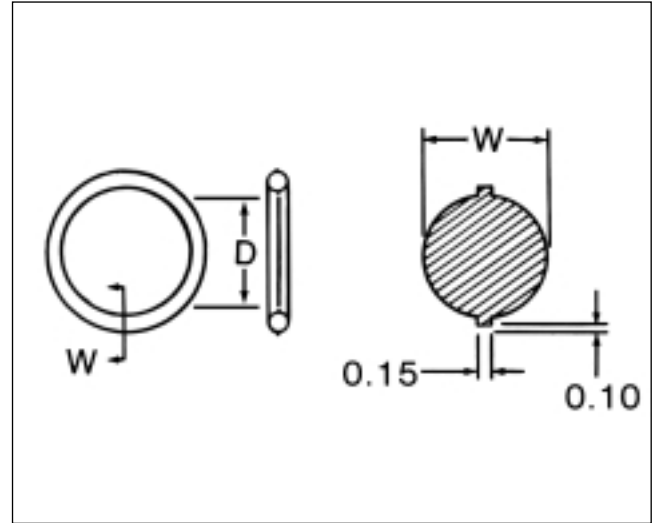

### How to Identify O-Ring Pilot Thread Sizes

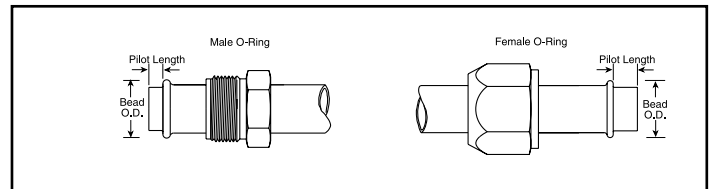

This connection is common to air conditioning systems, both in vehicle and commercial applications. Both the male and female halves of the connections have a pilot, either long or

short. The seal takes place by compressing an O-ring adjacent to the bead of the tube. The threads hold the connection together mechanically.

Inch Size	Dash Size	Male Thread O.D. (Inch)			Female Thread I.D. (Inch)		
		Nominal Thread	Fraction	Decimal	Nominal Thread	Fraction	Decimal
3/8	06	5/8 - 18	5/8	.62	5/8 - 18	9/16	.57
1/2	08	3/4 - 18	3/4	.75	3/4 - 16	11/16	.69
5/8	10	7/8 - 18	7/8	.87	7/8 - 14	13/16	.81
3/4	12	1 1/16 - 16	1 1/16	1.06	1 1/16 - 14	1	.99

Inch Size	Nominal Tube Size	Long Pilot		Short Pilot	
		Bead O.D. (Inch)	Pilot Length	Bead O.D. (Inch)	Pilot Length
3/8	06	.52	.28	.52	.19
1/2	08	.64	.39	.64	.19
5/8	10	.77	.39	.77	.19
3/4	12	.91	.39	.91	.19